

RF Power Capacitors Class1 15kV Hi-Load : Stand-Off Mounting

<p>Morgan Advanced Materials is a world leader in the design and manufacture of complex electronic ceramic components and assemblies used in a wide range of applications and cutting edge technologies. Morgan's Ruabon Division specialises in the development and production of dielectric and ferroelectric materials and components. This range of high voltage RF discs capacitors is fabricated from very low loss CLASS 1 ceramic dielectric materials which permit them to carry very high electrical loads over a wide frequency range.</p>	
<p>Applications include :</p> <ul style="list-style-type: none"> • Radio Broadcast Transmitters • Induction and Dielectric Heating Equipment • HF Filter, By-Pass & Coupling Circuits • High Power Matching Tuned Circuits • Antenna Circuits • Industrial Applications • High Power matching networks –Plasma Generators • High quality medical imaging systems (MRI) 	<p>Features :</p> <ul style="list-style-type: none"> • Low loss Class 1 ceramic dielectric materials with noble metal electrodes resulting in low self heating. • High Voltage / High Reactive Power Ratings • Very low NPO capacitance-temperature characteristics available that result in correspondingly low tuned frequency drift. • Low Inductance construction permitting higher frequency use. • Low magnetic susceptibility

Material Characteristics						
Dielectric Constant @ 20°C / 1MHz		15	36	77	90	190
Temperature Coefficient of Capacitance	ppm/°C	+100 ± 60	0± 30	0± 30	-750±80	-1300±120
Tan δ@1MHz (Cap ≤ 1000 pF)	x 10 ⁻⁴	≤5	≤5	≤5	≤5	≤5
Tan δ@1kHz (Cap > 1000 pF)	x 10 ⁻⁴	≤10	≤10	≤10	≤10	≤10
Dielectric Strength	kVmm ⁻¹ dc	22	20	15	10	10
Volume Resistivity	Ωm	10 ¹³	10 ¹³	10 ¹³	10 ¹³	10 ¹³

Electrical Specification	
Capacitance Range	400 – 4000pF (see table)
Capacitance Tolerance	±20% ±10% Consult factory for other tolerances
Rated RF Voltage	15 kVpk (see table)
Test Voltage (50Hz)	√2 x Rated Voltage / 60sec
RF Voltage / Current kVA_r Load v Frequency	See RF rating curves (ref 30°C max ambient temperature)
Operating Temperature Range	-25°C +95°C
Maximum Relative Humidity	75%

Outline Drawing 15kV Hi-Load : Stand-Off Mounting

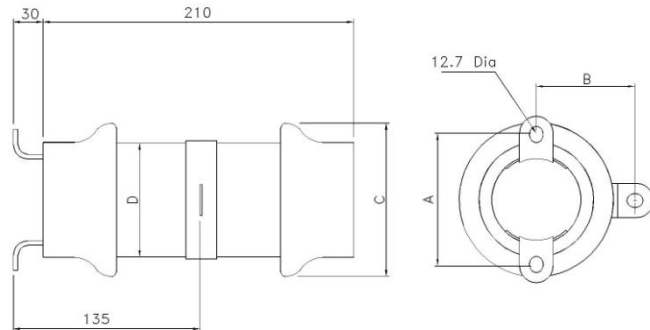

Hi-Load 15 kVdc : Stand Off Mounting

Electrical Characteristics

Type No	Cap Value pF	TCC ppm/°C	Rated (ACpk + DC) kVpk	Rated AC kVpk	Test 50 Hz kVrms	Max POWER Rating (kVAr)	Max Current Rating (A rms)	A nom (mm)	B nom (mm)	C nom (mm)	D nom (mm)
01	400	+100	15	15	15	500	70	100	82	131	100
01	500	+100	15	15	15	500	70	100	82	125	90
01	650	+100	15	15	15	500	70	100	82	118	85
01	1200	+100	15	15	15	500	70	100	77	110	77
02	2000	-750	15	15	15	200	60	85	70	116	85
02	3000	-750	15	15	15	200	60	85	70	107	76
03	3000	-750	15	15	15	275	70	100	82	128	96
03	4000	-750	15	15	15	275	70	100	82	121	90
96120/1	500	+100	18	18	18	500	70	100	82	125	90

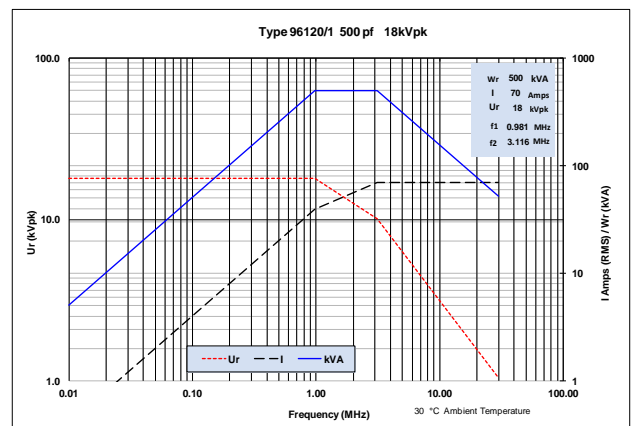
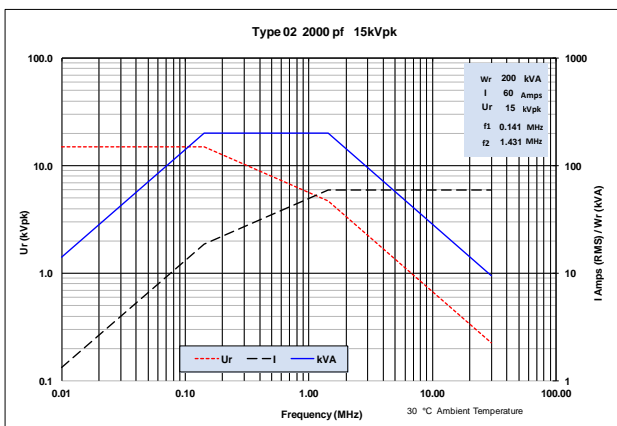
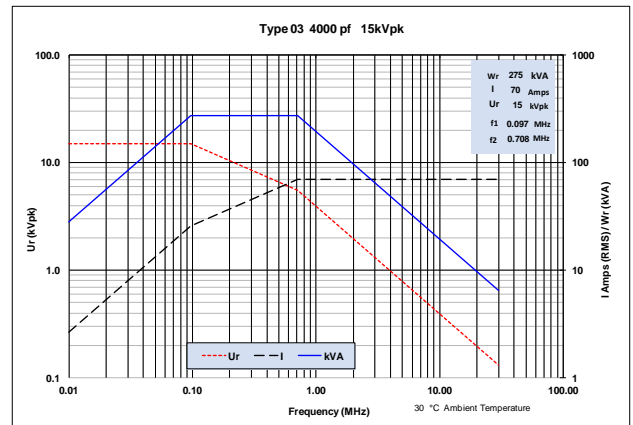
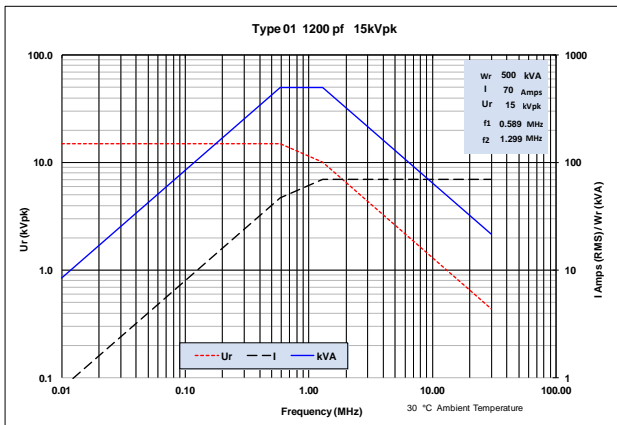
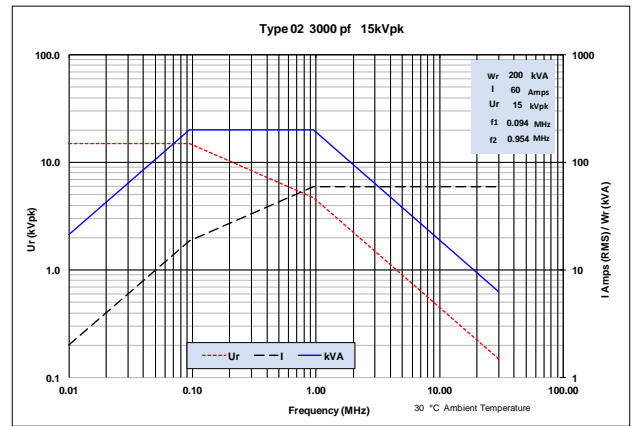
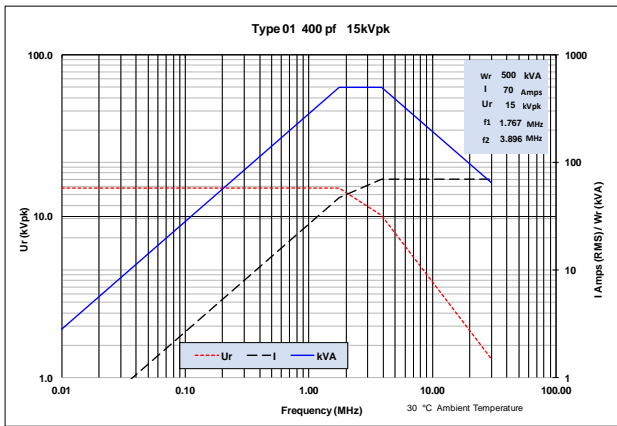

The above RF load conditions are based on the maximum body temperature rise of 45°C from an ambient temperature of 30°C.

Email technical / sales related enquiries to
ruabon.sales@morganplc.com

Please view our website :
www.morganelectroceramics.com

Links:

* Power Rating & Operating Conditions

Disclaimer: Please note that all product, product specifications and data detailed in this brochure are subject to change without notice to improve reliability, function, design or otherwise. Morgan Advanced Materials Ltd and its affiliates does not assume any responsibility for the correctness of this information nor for damages consequent to its use. Statements regarding the suitability of products for certain types of applications are based on knowledge of typical requirements that are often placed on Morgan products in generic applications.

Morgan Advanced Materials
Technical Ceramics
Vauxhall Industrial Estate
Ruabon
United Kingdom LL14 6HY