

The NL1037 ignitron is suitable for use as a switch for either capacitor discharge service or as an electronic crowbar, at peak voltages from a few hundred volts to 20 kilovolts, and peak currents up to 100 kiloamperes.

GENERAL DATA

Electrical:

Cathode Spot Starting	Ignitor
Number of Electrodes	
Anode -----	1
Cathode -----	1
Ignitors -----	1
Inductance (approximate) -----	20 nh

Mechanical:

Envelope -----	Stainless Steel
Anode Material-----	Graphite
Mounting Position -----	Axis Vertical, Anode Up
Net Weight -----	2 lb (0.91 Kg)
Diameter -----	2-1/8"
Seated Height (Nominal) -----	7-1/16"

Ignitor Ratings:

Voltage	<u>MIN</u>	<u>MAX</u>	
Open Circuit (Ignitor +)	1500	3000	V
Inverse (Ignitor -)	-----	5	V
Current, Short Circuit	100	250	A
Length of Firing Pulse, 1/2 Sine Wave	5	10	μs

Thermal:

Type of Cooling -----	Convection, or Liquid, by a water cooled clamp (p/n 1K1703 recommended) around lower portion of tube. (see page 5 for details)
Ambient Temperature -----	10 to 30 °C
Cathode Temperature (MAX) -----	35 °C
Anode Header Temperature (MAX) -----	55 °C
Anode to Cathode Temperature -----	(Note 1)

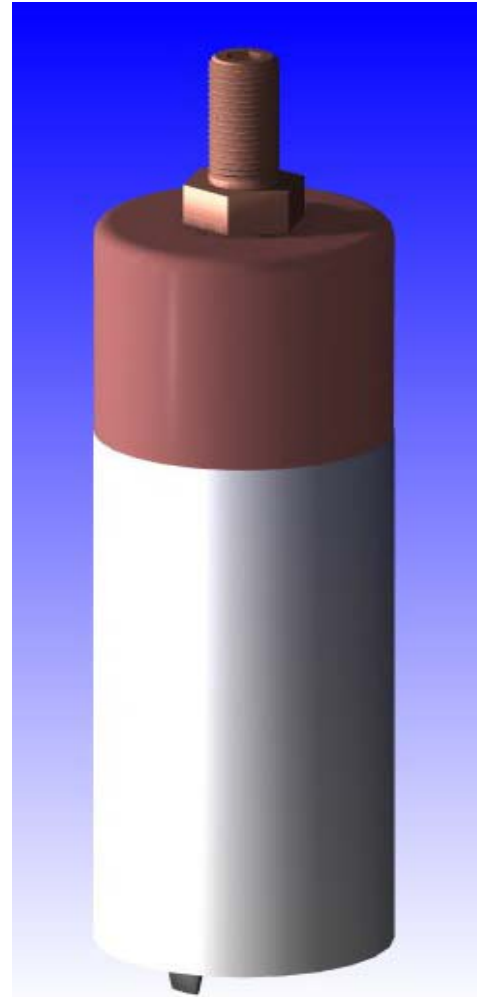

Feb. 2011

Maximum Ratings

	Damped Discharge		Ringing Discharge	
Peak Anode Voltage				
Forward -----	20,000	-----	20,000	V
Inverse -----	20,000	-----	20,000	V
Critical Anode Starting Voltage (MIN)	100	-----	100	V
Anode Current				
Peak -----	100,000	-----	100,000	A
Average -----	0.75	-----	0.25	A
Maximum Average Time -----	1	-----	1	Cycle
Length of Conduction -----	0.3	-----	20	mS
Rate of Rise of Current -----	(Note 2)	-----	(Note 2)	
Discharge (Rep Rate) Typical -----	2	-----	2	Per Minute
Total Charge (Per Minute) -----	30	-----	30	Coulombs
Ionization Time -----	0.5	-----	0.5	µs
Voltage Reversal -----	None	-----	50	%



WARNING! USING SIMULTANEOUS MAXIMUM RATINGS WILL SEVERELY DETERIORATE IGNITRON LIFE!

Notes:

1) To prevent mercury condensation on the anode and anode seals, the anode header temperature should be 10°C higher than the cathode temperature at all times. Before operation, elevate the temperature of the anode area, with respect to the cathode, long enough to remove any mercury from the top portion of the ignitron.

2) Rate of rise depends upon the external circuitry.

Tube Life Considerations

The method used to determine the life expectancy of an ignitron varies according to the application and it is necessary to consider the various types separately. It must be understood that the ratings specified are absolute limits. It is the responsibility of the equipment designer to ensure that the specified limits cannot be exceeded under the worse possible conditions of component tolerance, voltage fluctuation, and load variation.

A general rule of thumb: To obtain longer life, the ignitron must be operated at lower levels. Typically, life may be increased 10X if either the voltage or current is halved.

Ignitrons are robust high current switching devices. The current ratings may be exceeded to some extent without destroying the ignitron but with the consequence of reduced life.

IGNITOR

The ignitor is a small rod of semiconducting material with a pointed end that is partially immersed into the cathode pool. When a suitable current pulse is passed through the ignitor-mercury junction (with the ignitor being positive with respect to the cathode pool) forms a cathode spot on the surface of the mercury and free electrons are emitted. If the anode is sufficiently positive with the cathode at this time, an arc will form between the cathode and anode. Once the arc is initiated, the ignitor has no further control and the ignitron continues to conduct until the voltage across the ignitron falls below the ionization potential of the mercury vapor.

In capacitor discharge circuits the ignitron has to pass a very high current and the conditions are naturally harmful to the ignitron. The mercury pool and the ignitor itself will become contaminated and the best life will be obtained if a high energy pulse is applied to the ignitor. Under these conditions a pulse from a separate excitation circuit containing a 1µf capacitor charged from 1500V to 3000V will provide 1 to 4.5 Joules of energy to the ignitor. Richardson Electronics endorses National Electronics Ignitrons using these parameters. Considering the wide range of ignitors available across the range of ignitrons produced, Richardson Electronics recommends that an ignitor pulse providing 4 to 7 Joules is optimal.

MOUNTING

The performance and life of the ignitron is greatly improved if it is operated in a field free space. Magnetic fields tend to force the arc toward the tube sidewall and aggravate sidewall arcing. Metal vapor produced by sidewall arcing is one of the major contributors to ignitor wetting. We recommend a coaxial type mounting to minimize field effects. See Page 5 for details.

INSTALLATION INFORMATION

RECOMMENDED CONDITIONING BEFORE INITIAL USE - The ignitron is in high voltage operating condition before leaving the factory. Shipping tends to redistribute mercury throughout the ignitron making certain conditioning steps desirable before installation.

Heat Conditioning - Before applying voltage, heat anode stud to 100-125°C (keeping cathode near room temperature) for two hours minimum. This drives mercury away from anode and anode seal area.

Voltage Conditioning (after Heat Conditioning) - Apply 110% of operating voltage (preferably DCV) or up to 110% of rated maximum voltage across ignitron (anode positive and ignitor not connected) with a series combination of a 1 to 4 uf capacitor and a 1 ohm resistor in parallel with the ignitron. NATIONAL will replace any ignitron that will not hold off minimum voltage at initial test when caused by a manufacturing defect. Additional conditioning at higher voltages is recommended to stabilize the ignitron after shipping. Slowly increase voltage above minimum. Breakdown may occur but the ignitron will attain a Hi-Pot Stabilization Voltage of approximately 125% of operating voltage, or up to 125% of rated maximum voltage.

NOTE: The time required for conditioning to Hi-Pot Stabilization Voltage can be reduced by using a variable ac voltage source connected directly across the ignitron (ignitor not connected). Slowly increase the voltage; limit the current to 30 milliamperes maximum.

RECOMMENDED PRACTICE AFTER INITIAL USE - Mercury condensed in the anode and anode seal area greatly decreases the ignitron's voltage hold-off ability. Heat conditioning before initial use complements proper mercury distribution before the ignitron is first placed in operation. Once in operation, maintain a thermal gradient so that the anode area is at least 10°C greater than the cathode. This is also true during any cooling period. The anode and anode area must not cool faster than the cathode.

The ignitor becomes susceptible to damage by movement of mercury after use in a capacitor discharge or crowbar application. For maximum life, we recommend that an ignitron not be moved until end-of-life once it has been placed in service.

LIFE AND WARRANTY

Richardson Electronics, Ltd. warrants the tube types listed above to be free from defects of design, material, and workmanship when received and, after receiving Recommended Conditioning Before Initial Use, to operate satisfactorily when first installed and, if used within ratings, to give a minimum of 1000 operations. No adjustment will be made if the tube is not placed in service within six months after date of shipment by manufacturer. This warranty expires 12 months after date of shipment by manufacturer.

National High Voltage Switching Ignitrons have an expected life of many times the warranted number of operations in most applications. Operating within the recommended ratings and following the *Recommended Practices After Initial Use* will greatly increase the life or operations obtained.

AVAILABLE ACCESSORIES

Part Number	Description
1K1703	Coax Mounting Adapter (See page 5)
1M2602	Ignitor Tulip Clip Connector (See page 5)
1K958-Series	Ignitor Tulip Clip/Cable Assembly (Various options available, check with your local Richardson representative for details.)
IG5F2-10	Ignitor Trigger Module (Works on all National Ignitrons.)

OUTLINE DRAWING

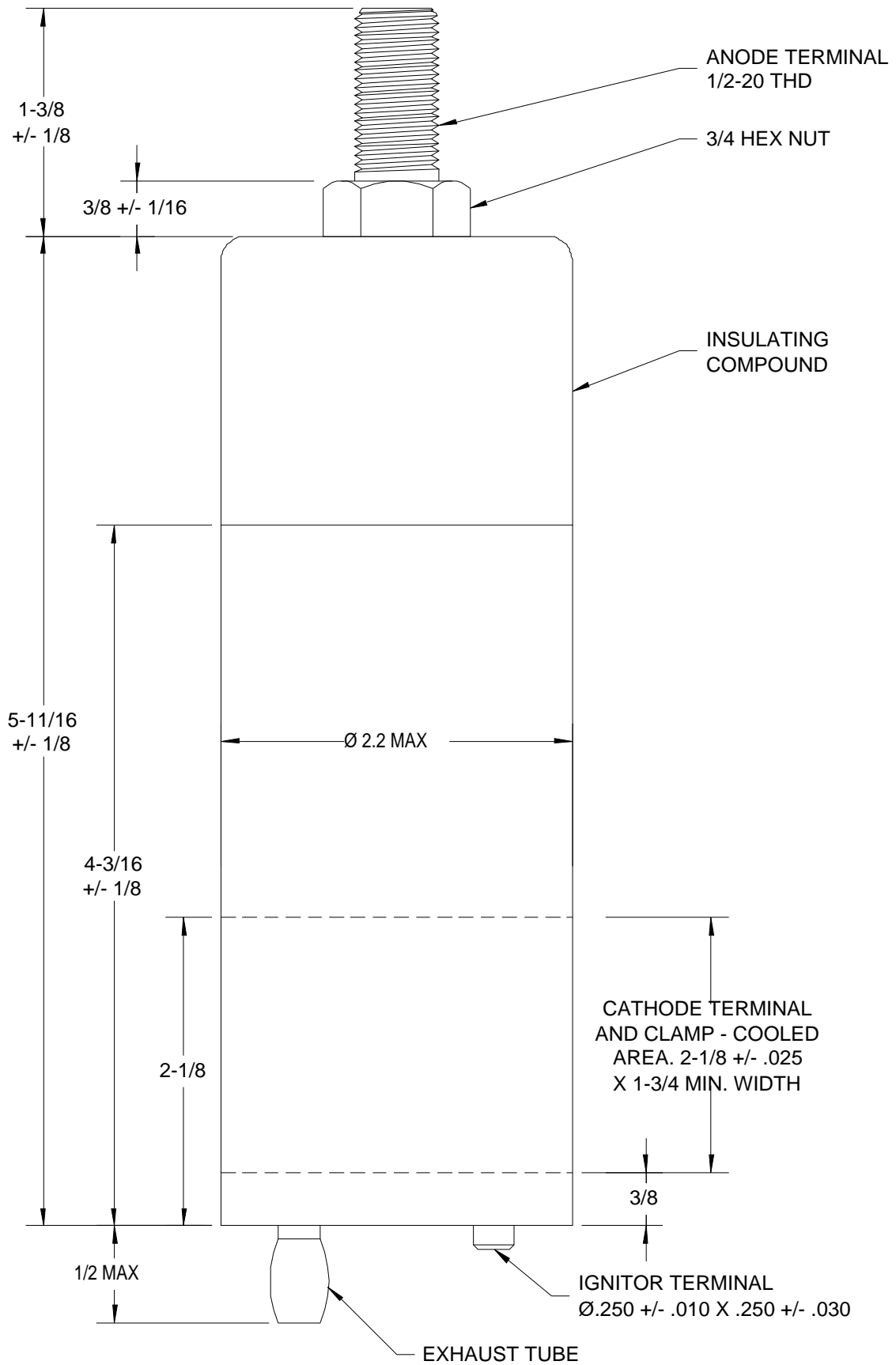

Recommended Mounting Procedures:

1. Mount the 1K1703 Coax Mounting Adapter to the chassis of your equipment, See Fig 1.
2. Insert the tube into the 1K1703 and tighten the hose clamp using a screwdriver or nut driver.
3. Attach the anode connection bar (supplied by the customer) and thread on the captive nut. **HAND TIGHTEN ONLY AT THIS TIME.**
4. Loosen the hose clamp on the 1K1703 and then using two opposing wrenches tighten the captive nut to secure the anode connection in place, as shown in Fig. 2. **DO NOT PUT UNDUE STRESS (>20 ft.lb) ON THE ANODE OF THE TUBE. THIS WILL CAUSE THE GLASS TO CRACK, LOSE VACUUM AND VOID THE WARRANTY!**
5. Position the tube in the 1K1703 so that the tube will be clamped in the correct area (see the outline drawing on page 4) then tighten the hose clamp to secure the tube in place.
6. Connect water cooling lines to the 1K1703 with hose clamps (not supplied).
7. Connect the ignitor terminal to the ignitor, as shown in Fig. 3. **DO NOT APPLY SIDWAYS FORCE TO THE IGNITOR TERMINAL. DOING SO CAN CAUSE THE GLASS INSULATOR TO CRACK AND THE TUBE WILL LOSE ITS VACUUM AND VOID THE WARRANTY!**

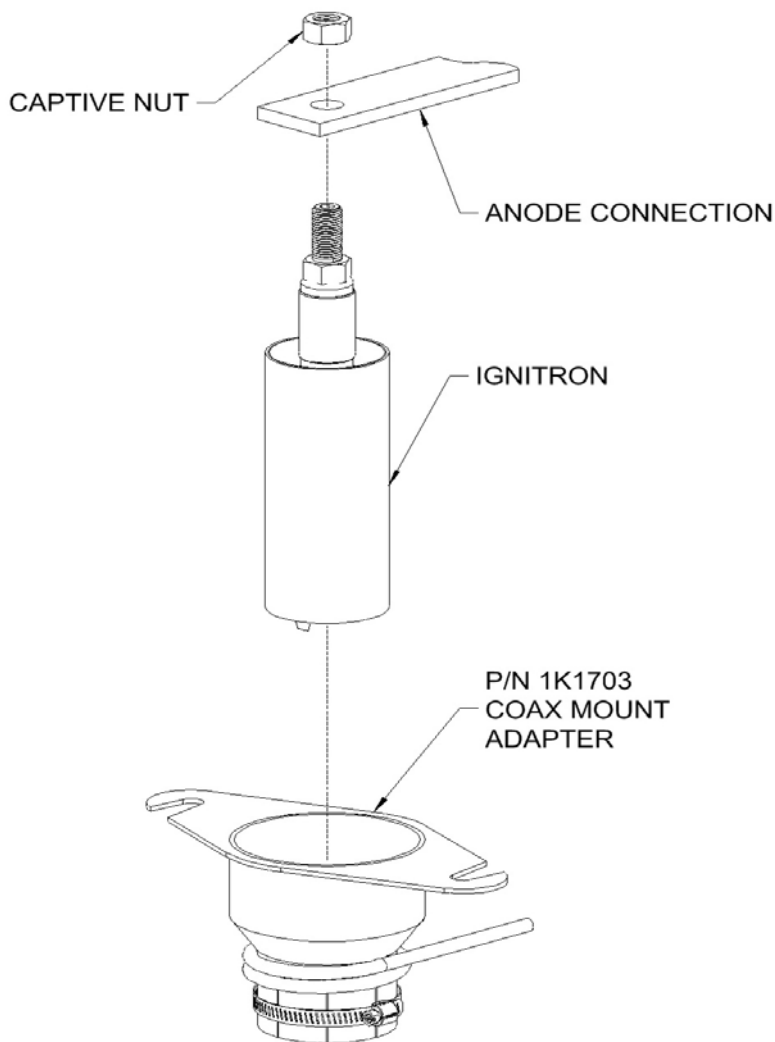

Fig. 1

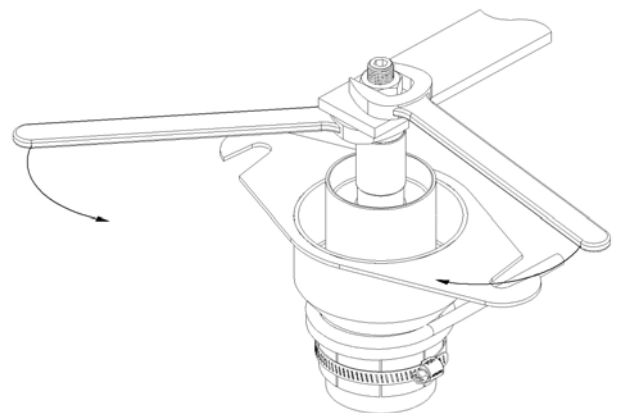

Fig. 2

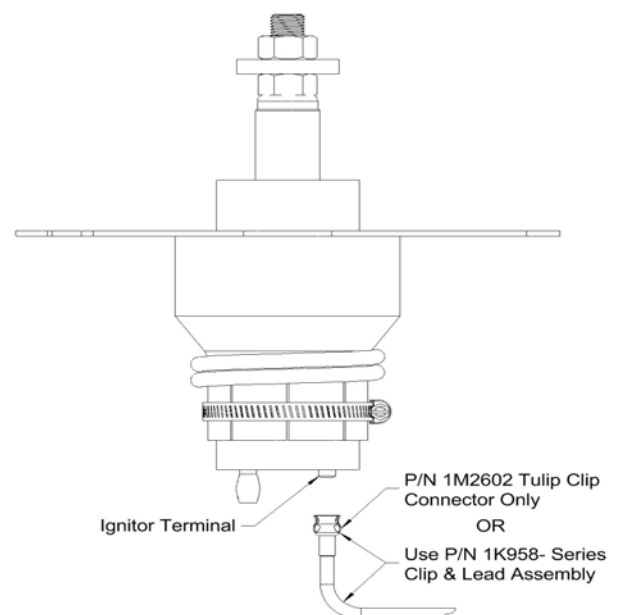

Fig. 3